

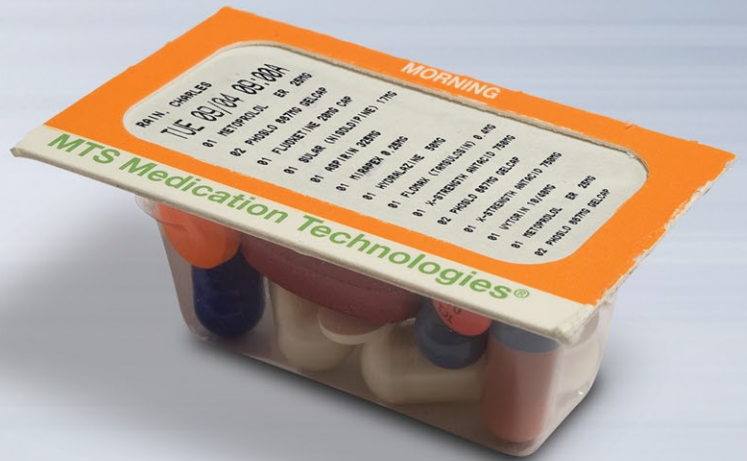

Safer. Faster. Easier.





• RxMap® Adherence Packaging: Provide your customers with the tools to stay healthy.

Lack of medication adherence is not only dangerous—it's the fourth leading cause of death in the United States. It costs the health care system upwards of \$150 billion annually. Estimates are that only 50 percent of patients typically follow doctors' orders when taking prescription drugs, and other studies show that non-adherence is responsible for many hospital and nursing home admissions.

Better patient health can be achieved through more than just medication. Adherence tools, such as multi-med packaging, can have a significant impact on patient health and safety—especially when it comes to complicated regimens.

To address adherence concerns, MTS has developed a multi-med punch card and system—RxMap. The RxMap System (Multi-Med Adherence Packaging) was developed to make adherence easier for patients, caregivers and health care providers.

This sealed, tamper-evident package makes it easy for RxMap users and caregivers to tell if medication has been taken. Other systems, such as pouch, do not serve as visual reminders and can lead to additional confusion when it comes to complicated medication regimens. Other alternatives, including pillboxes, can become contaminated over time.



Reasons Cited for Poor Medication Adherence

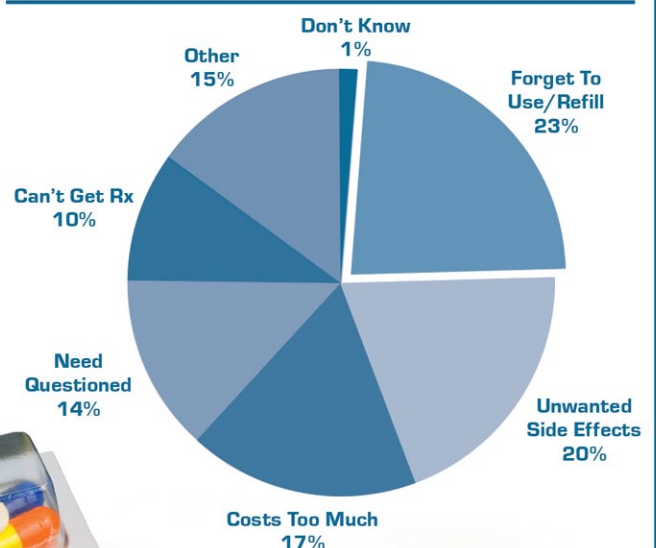

BCG analysis, Harris Interactive 10,000 Patients Survey, 2002
©2008 CIGNA Pharmacy Management. All rights reserved.

Source: Thom Stombaugh, CIGNA Pharmacy Management

RxMap® – Packaging, software and automation.

The RxMap (Multi-Med Adherence Packaging) System is designed to increase patient adherence and health, while decreasing health care costs. The final product created by this system is a multi-med punch card designed to help patients stay healthier through simple adherence principals. This system is available in three packages that are designed for your pharmacy's various needs and volume requirements.

1. Packaging - RxMap (multi-med adherence packaging)

No printers or additional equipment is necessary—just your RxMap punch cards.



2. Software - Patient label and workflow software

Add printers that will produce consolidated labels and printed foil backing.

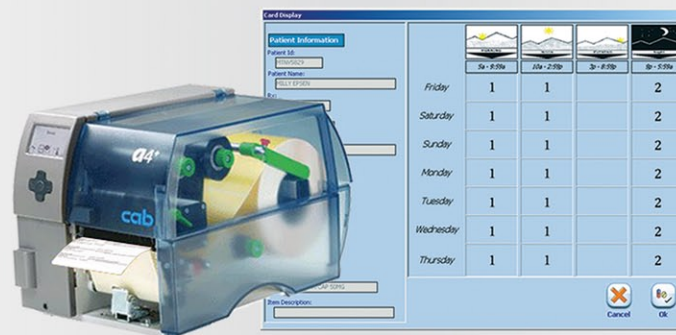

3. Automation - OnDemand® 400 for RxMap®

Automate the dispensing process of your RxMap cards.



RxMap is the easy-to-use multiple medication adherence blister card. The software is interfaced to your pharmacy management system for prescription labeling, workflow optimization and medication validation. The entire process can be automated with the OnDemand 400 for RxMap.

MTS - a trusted adherence packaging provider for more than 25 years.



Who is using RxMap?

Independent pharmacy patients who need help with difficult regimens.

During a recent visit to an independent pharmacy, we learned that the pharmacist had spent several weeks working with an elderly patient to simplify her difficult regimen. This patient had to take several medications throughout the day and was failing to stay adherent, because she was confused about what to take and when. Not surprisingly, this patient was unable to derive maximum health benefits from her medications.

When presented with RxMap, the pharmacist was very excited to finally have a tool that would help patients with difficult-to-follow regimens; not to mention, the pharmacist was no longer burdened with finding a solution.



Pharmacies looking to increase market share with a new product offering.

Some pharmacies have completely saturated their long-term care market, but would like to continue expanding their business. Taking on new business with group homes, mental health facilities and other special needs clinics, such as HIV/AIDS patients, will help achieve new growth. These facilities serve patients that take several medications throughout the day, so they benefit greatly from the organization and ease that RxMap offers.

Offering RxMap allows pharmacies to branch into new customer segments, enabling growth and differentiation from the competition.

Caregivers searching for simplified regimens.

Mrs. Jones drives three hours to an assisted living facility (ALF) to visit her husband of 49 years. During recent visits, she noticed a decline in his mental and physical state. When she asked if he had been taking his medication, he expressed how difficult it was for him. Mrs. Jones quickly noticed her husband's complicated medication regimen. With eight medications to take throughout the day at different times in different quantities, it is no wonder he was beginning to fall ill again. Mrs. Jones spoke to her pharmacist and asked if there was any way to simplify her husband's regimen. The pharmacist was more than willing to help and offered RxMap as a solution.

RxMap organizes medication, making it easy for patients to stay adherent and gives caregivers a peace of mind.



MTS - a trusted adherence packaging provider for more than 25 years.



RxMap® Packaging

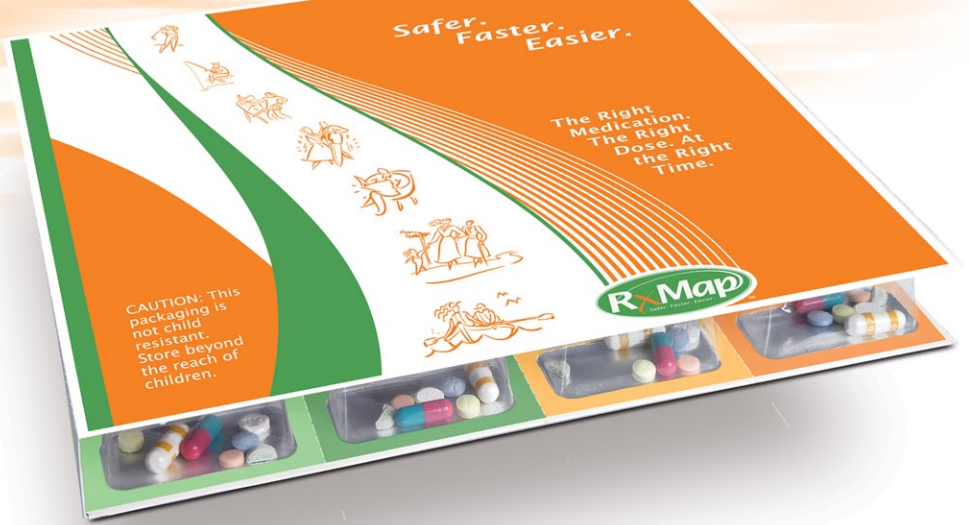

RxMap is a punch card for multiple solid oral medications organized by time of day and day of the week. This punch card provides visual reinforcement of what to take and when.

RxMap (Multi-Med Adherence Packaging) is organized in a format that is familiar to patients and caregivers. With a tamper-evident seal, users can see at a glance whether a medication has been taken. In addition, some cards are color-coded, so users will know when to take their medication even if the time-of-day container has been detached from the card.

Some RxMap cards are perforated, allowing the patient to detach and take their time-of-day containers with them.* These individual blister containers are perfect for those on-the-go patients, because they can be easily removed from the larger card and carried in a pocket or a purse.

RxMap Blister Containers

RxMap blister containers are available in different sizes, depending on your medication requirements and the number of medications that need to be printed on the foil.

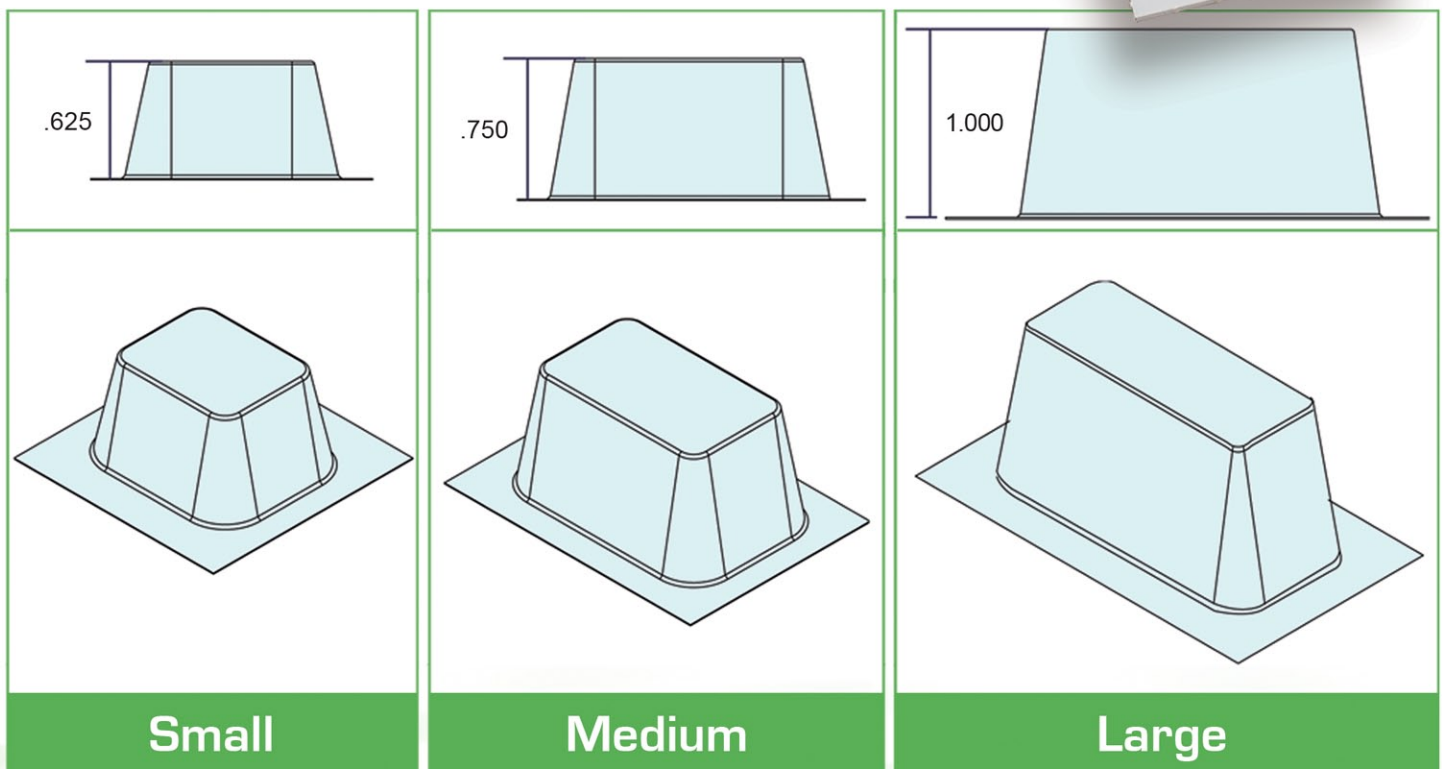

* Perforated individual compartments can be labeled with patient information and medication instructions if required by regulations and guidelines.

Which size is best for my pharmacy?

The largest RxMap container can hold approximately 14 medications. Information for each medication must be printed on the back of the detachable time-of-day containers, which can hold 14 lines of medication information. Plus, multiple doses can be represented on one line. Other multi-med punch cards and pouches do not have the space needed to print all of the medication information, so multiple containers may be required for one time pass.

Time Pass with RxMap



16 medications - 1 container

Time Pass with Other



16 medications - 4 containers

To determine what size is best for you, consider:

1. The amount of space required to print medication information on each time-of-day container
2. The quantity and size of the medications

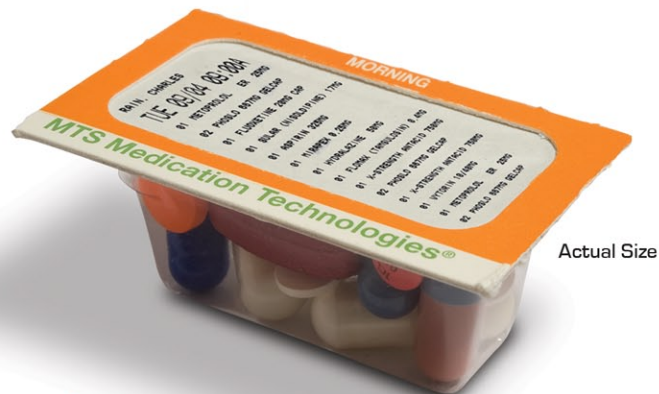

Actual Size

Time-of-day container

(Contains 14 medications and 17 pills.)

MTS - a trusted adherence packaging provider for more than 25 years.

Perforated RxMap Card Formats

RxMap punch cards are available in different formats and sizes for various needs. Card sizes vary, as well as the size of the individual time-of-day containers. These formats include:



- 7-day, 4-Time Pass (small, medium and large)



- 7-day, 4-Time Pass, 3 color (medium)



- 7-day, 2-Time Pass



- 30-day (medium)

Blister Container:

The ideal size blister container for your customer will depend on the quantity and size of medications. Also, if printing on foil the number of medication names that need to be printed will also be a factor.

Perforated Packaging:

Each time-of-day container can be detached from the larger card for ambulatory patients who are on the go.

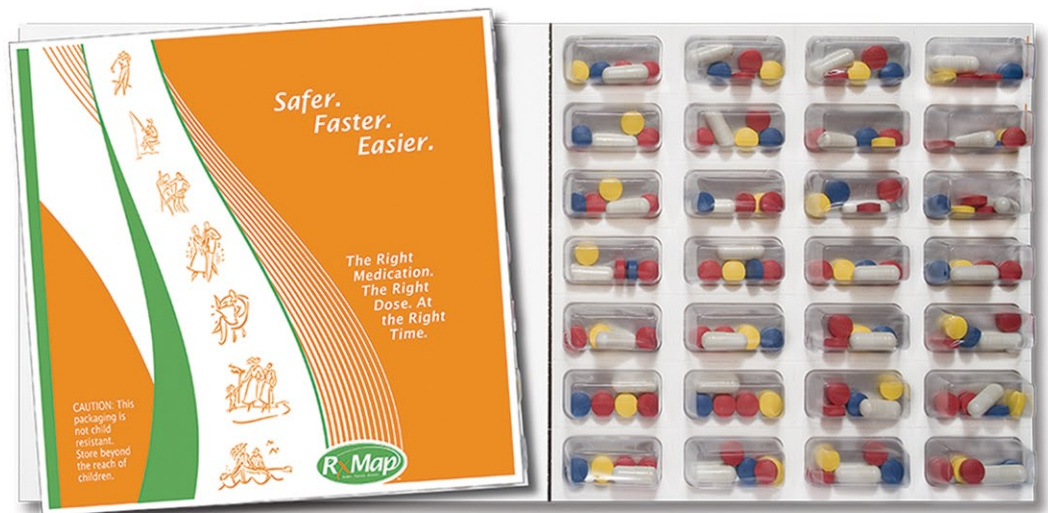

- 28-day medium, large (large capacity or small capacity)

**Customize
Your
Card.**



All RxMap packaging can be customized with your company's brand design. This specialized touch will give your pharmacy an advantage over the competition and provides additional exposure with your customers and prospects.*

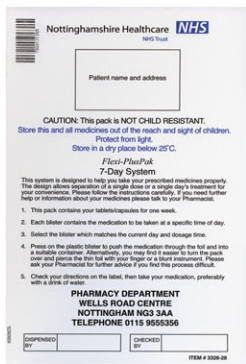
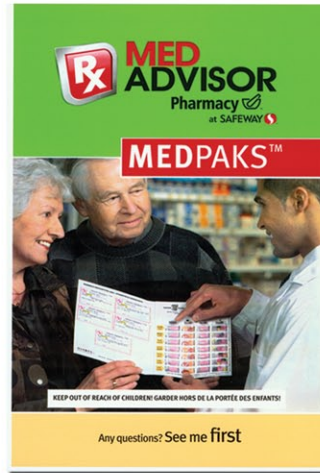
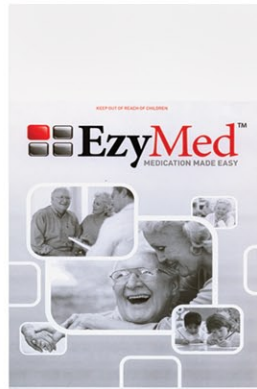

INTRODUCING SIMPLY YOURS™ —THE ULTIMATE SOLUTION FOR PATIENT COMPLIANCE

Debuting mid-2007 is Simply Yours,™ a personalized and convenient program formulated to address each patient's specific nutraceutical needs. Simply Yours allows healthcare professionals to combine their patient's specific recommended supplements in a convenient daily AM and PM regimen organized intelligently by week.

- Key benefits of Simply Yours include:
 - Simplified dispensing
 - Improved patient compliance
 - Enhanced patient outcomes
 - Increased portability (Patients can perforate by time or day for travel or if they need to haul bottles)
 - Simplified dosages for AM to PM
 - Simplified and week to week

■ Made of 100% recyclable materials



*Minimum order requirements apply for custom RxMap packaging.

OnDemand[®] 400 for RxMap[®]

**Changing
the way
medications
are dispensed.**

Interfaced to Your Pharmacy

Downloads label information from your operating system, collates prescriptions and schedules the automatic fulfillment of Multi-Med Adherence Packages.



Automatic Prescription Label Applicator

Each Multi-Med Adherence Package has a unique bar code that is scanned before and after the package is sealed ensuring the label and medications match. All prescription data for a specific Multi-Med Adherence Package is collated and printed onto one (or if needed, two) large format label that is automatically applied to the inside cover.



**Changing
the way
medications
are dispensed.**

OnDemand[®] 400
for **RxMap[®]**

OnDemand 400 for RxMap is the first automation system designed specifically for multi-med adherence packaging. This efficient system uses OnDemand technology to dispense multiple medications for a single patient quickly and accurately – and in a fraction of the time it would take to do manually.

The system interfaces with your existing information system. This single data input process reduces input time and the possibility of data entry errors.

OnDemand 400 for RxMap uses bar code technology to accurately dispense multiple medications into one compartment — as many or as few as needed. Multi-Med Adherence Packages vary in size and shape to meet the needs of the customers you serve. The finished product is a patient-specific adherence package filled on demand for your customer.

OnDemand automation gives you the tools to control the workflow in your pharmacy. One such tool is the

software's "Fill Scheduler" feature. Fill Scheduler allows you to preview your workload for upcoming weeks. You can then take that information and use the system to quickly and efficiently schedule the pharmacy workflow.

For example, Fill Scheduler shows you that on Friday, June 6, you will have to fill an unusually large number of prescriptions. You can use the system to redistribute the workload by making a slight increase in the number of prescriptions filled each day that week. This evens out the workload between the days and averts the stress that your staff typically experiences with an extra heavy workload.

Increase Operational Efficiency

With OnDemand automation, you can also increase the pharmacy's operational efficiency by scheduling prescription fills for an entire facility on the same day. This is particularly beneficial when many of the facility's patients are on the same medications, such as a mental health facility or a clinic that specializes in HIV/AIDS patients.

Effectively Manage Inventory

The system also provides the tools for you to effectively manage the pharmacy's inventory. By identifying which medications you will need for upcoming patient fills, the software enables you to order the required medications a short time before the fill date. This allows you to avoid the significant expense and administrative burden associated with maintaining an extensive medication inventory in the pharmacy.



The operator at the fill, seal and labeling station.



The finished card about to be labeled.

MTS - a trusted adherence packaging provider for more than 25 years.

Automated Packaging System



Heat-Sealing Press

Following visual inspection, the package is sealed in a high-pressure station to provide a secure, tamper-evident package.



Perforated Compartment

Medication compartments are a “stand alone” container for medication. Adherence Packages are fully reusable parts that must be re-

MTS - a trusted adherence packaging provider for more than 25 years.

For Multi-Med Adherence Packs.



Foil Printer (optional)

Patient and medication information printed directly onto the foil backing.



Cassette Technology

Oral solid medications are taken from bulk inventory and placed into drug-specific cassettes. Each cassette has a sensor with a unique code. Using RFID (radio frequency I.D.) technology, this unique code is used to notify the user when a cassette has been added or removed from a feeder base.

Perforated & Disposable Packaging

Perforated – making each one easy to take on-the-go for your on-the-go patients. MTS packaging is fully disposable, with no expensive components that are recycled through the pharmacy.



Customized Packaging

Multi-Med Adherence Packages are available in different sizes and formats and can be customized to brand your pharmacy's service. The Packages inside cover provides the space to clearly label each prescription and associated instructions. The individual blister can be labeled with:

- Patient's name
- Date and time to be administered
- Name of drug, strength, dosage form and quantity

“ Before automation, we spent about 6-8 hours filling multi-med packaging each day. With OnDemand 400 for RxMap, we run the machine for 2 or 3 hours a day and doubled our volume. ”

Pharmacy Manager



2003 Gandy Blvd. North, St. Petersburg, FL 33702

T (800) 671-0589 F (800) 671-0588 W www.mts-mt.com